



RaceLink and CAN Project Pro Units

Description & Technical Specifications

Versions			
v1.0	01-Jan-2020	Scott Smart	Document Creation
v1.1	05-Jan-2020	Scott Smart	Headers
v1.2	19-Jan-2020	Scott Smart	Style
v1.3	15-Mar-2020	Scott Smart	Added Contents, Pinouts, CAN Messaging Details
v1.4	02-June-2020	Scott Smart	Added details to message including compulsory/non compulsory etc
v1.5	16-June-2020	Scott Smart	Added source and target information to message summary table
v1.6	25-Aug-2020	Scott Smart	Added more information indicating whether data should be shown to rider
v1.7	25-Nov-2020	Scott Smart	Appendix 4 spare parts
v1.8	26-Nov-2020	Scott Smart	Flag cancel column

UPDATED 10/8/24



Contents

- 1 Introduction**
- 2 Main Purpose**
- 3 RaceLink Bike Installation**
- 4 Installation Connection**
- 5 Baselink**
- 6 CAN Messages**
- 7 Appendix 1: Technical Specification**
- 8 Appendix 2: Pinout Detail**
- 9 Appendix 3: CAN Message Detail**
- 10 Appendix 4: Spare Parts**



Foreword:

This document includes struck out information. It is included here for completeness to show how the system is used in World Championships and because you may have systems that have been derived from World Championship settings.

We are working closely with Mylaps to ensure that the flags and rider messaging are implemented very soon using this common protocol. There 'may' be some small updates due to some ongoing work by MotoGP and WSBK.

1.-Introduction

RaceLink is a new technology developed by MyLaps improving current two-way communication's and adding new features like GPS tracking.

The RaceLink technology consists of a RaceLink Pro ('**RL**') (device installed on the vehicles) and BaseLinks '**BL**' (fixed transceivers placed around the circuit to communicate with the RaceLink Pro). Data transmission is via radio frequency utilising the 2.4GHz band.



RaceLink Pro



BaseLink



2.-Main Purpose

The RaceLink technology improves the current bi-directional communication between the Timing Servers and the vehicles CAN bus and the connection covers the complete circuit instead of just the moments whilst passing the timing loops. This allows Race Control and Timing messages (possibly later Team messages) sent to the bike to be received immediately, at any point of the circuit, opening new opportunities to new types of messages i.e. yellow flags by 'dynamic' sectors and timing messages like session time remaining.

The GPS on the **RL** will provide live data on the real position of every vehicle (bikes, medical and safety cars) with a **RL** installed. It is used for timing purposes and allows Race Control to see the live position of all vehicles at any moment - especially in the case of an interrupted session when is difficult to control all the vehicles on the track. During the races, even if the X2 transponders fail, it is possible to check if bike is stopped and where is it, if it is still on track or if it is being transported back to pit boxes. This will help Race Direction with the automatization of crash detection and procedure. It is also useful for an easy view of a long lap penalty or shortcuts traces and potentially defining virtual crossing points (no timing point) instead of installing a new loop.

The **RL** is NOT used for official timing – the X2 Transponder must remain correctly fitted and operating at all times.

This new system can also provide crash data, speed, position, etc... which will be a great assistance in developing run-off areas, injury statistics and develop rider' protective clothing and so-on.

Live data could later also be used to generate on screen graphics for bikes that are not carrying the onboard camera system.

Having this live communication with all the vehicles simultaneously transmitting data through the bike's CAN bus to the RaceLink Pro, new data analysis can be performed in order to, for example, clarify incidents between riders. TPMS messages and another new data (G forces in an accident) also can be sent using this new technology.

The system has been used since the 2018 season in WSBK. MotoAmerica is the first domestic series to embrace the technology and there will be a staged roll out of the features. We are working closely with Scott Smart of Dorna and MyLaps to ensure we get the best from the system.

Having all the bikes equipped simultaneously but still having coverage all around the track which will permit improving the communications with the bike in terms of Teams, Race Control and Timing messaging, as well as tracking all the bikes and safety/medical cars in real time.

In 2026 we plan to implement this technology in all classes.

As a developing technology updates may be required to equipment and its installation throughout 2025. With the knowledge already gained we aim to disturb teams as little as possible and hope that teams understand this process.

3.-RaceLink Bike Installation

The setup installed on the bike consists in 3 components.

- RaceLink Pro '**RL**'
- RF Antenna
- GPS Antenna

The **RL** should be mounted following **RL** manufacturer suggestions and must be noted that the **RL** needs to be placed as close as possible to the RF antenna in order to make the cable connection shorter and minimise the signal attenuation.

- Make sure the GPS antenna has a clear view to the sky at all times during racing conditions
- GPS CAN be mounted beneath fibreglass bodywork but NOT beneath carbon.
- Neither GPS nor RF can be mounted lower or shielded by other metal objects such as the subframe, consider that metal or carbon blocks the signal.
- Make sure the RF antenna is placed as high as possible on the vehicle having a clear view around the vehicle at all times during racing conditions
- Do not place the RF antenna next to other RF antennas. Keep at least 1m distance (for example the onboard camera system or TPMS system)
- You should aim to keep the RF cables as short as possible for both the RF aerial and GPS antenna if they are used.
- Place the device in an area of the vehicle where the temperature does not exceed 60 °C

Considering these requirements the **RL** setup should be installed at the rear of the bike for better performance and to avoid interference.

It is responsibility of the team to ensure that the system is installed on the bike according to these guidelines and that the system is functioning correctly. . If there is no connection to the device or the signal is bad it will be considered in the same way as a transponder that is not functioning.

We will work with you but not define the exact mounting position (eg the front may be a better solution in some cases).





4.-Installation Connections

As stated in the regulations the **RL must** be connected to the same CAN bus as the following items: MyLaps X2 Transponder (when using PRO), ECU, TPMS system, dashboard and preferably a data logging system.

RL must be powered by the bike and remain powered throughout the whole session (this also includes the, MyLaps X2 Transponder and TPMS system). It must not be switched off by the engine kill switch. The **RL** contains a small backup battery – which is in case of crash, it is not to be used for general operation.

If mounted on top / in front of the dashboard inside the screen (but not shielded by carbon fibre fairings) is successful but take care of RF interference caused by switching noise for dash screen backlights.

Do not overtighten the RF connections (take care if using a spanner) you WILL break the unit internally.

5.-BaseLink

The BaseLink will receive the data from those RaceLink Pro's moving around the circuit.

A set of BaseLinks will be installed the previous days of a Grand Prix around the circuit. The number will vary depending on the track layout. The target is to achieve a 100% coverage of the track and boundary / run off areas.

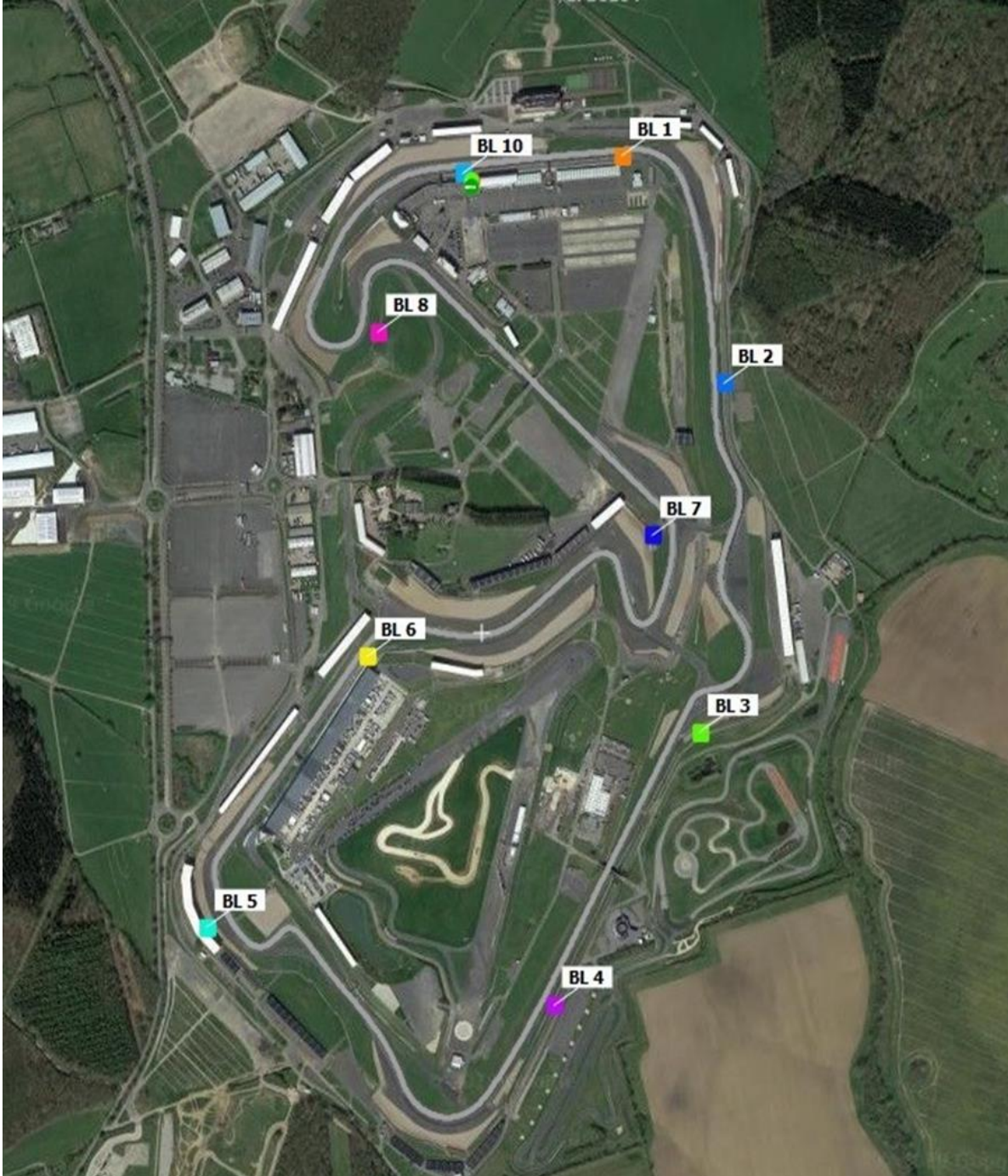



6.- CAN Messages

For 2025 the Racelink messaging system will become principal communications between the Timing Servers and the vehicles. Software development will oversee the message delivery, so there will be no duplicated messages.

See Appendix for CAN message Info

7.-Appendix 1: Technical Specifications

[Link to 3D Model of the Unit: contact bsbtechnical@msvracing.co.uk](mailto:bsbtechnical@msvracing.co.uk)

RaceLink Pro:

Dimensions

75x45x24mm / 3x1.8x1in

Weight

85g / 0.19lb

Operating voltage range

7 to 18VDC typical 12V

Power consumption

1.3W, 110mA@12V

Back up battery lifetime

Up to 8 hours

Back up battery charging

1:2 ratio, 4 hours for full charge

Operating temperature range

0 to 60 °C / 32 to 140F

Humidity range

10% to 90% relative

Positioning

3 concurrent GNSS reception

Sensitivity

-167dBm, 72 channels

Update rate

5Hz

GNSS antenna connection

SMA(F), 3.0V active antenna

RF Antenna connection RP-SMA(F)

RF output

+20dBm@2.4GHz ISM

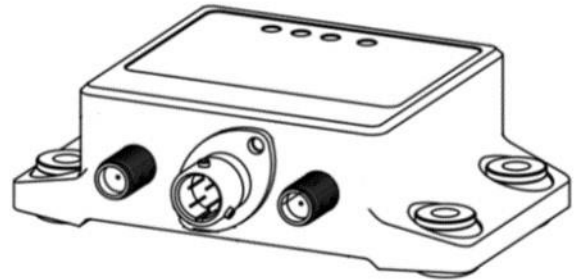



COMPETITOR BULLETIN 13-2025

Deutsch connector pin-out

Deutsch ASU003-05PN

P1 = 12VDC

P2 = GND

P3 = CAN L

P4 = CAN H

P5 = Timing signal input – connect to Pin5 of the X2 transponder (for future use)

Harness side connector:

Deutsch ASU603-05SN

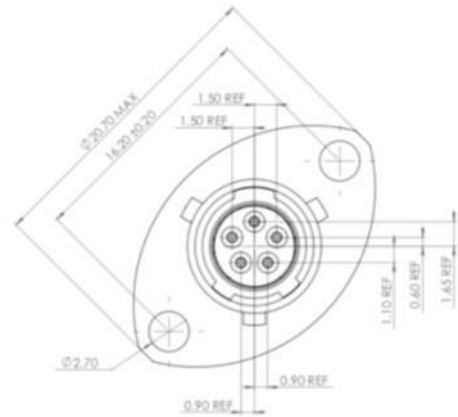



RF Antenna (CVL Covert, Flat,
Stick On)

Dimension

2.41" L x 0.65" W (61.1mm
x 16.5mm)

Cables

8 ft. long RG-174 standard

Connectors

SMA Plug (Male)

Shock and Vibration

IEEE1478, EN61373, MIL-
810G, TIA 329.1-C

Water Ingress IP69

Frequency

2.4-2.5 GHz - 4.9-6.0 GHz

Gain

3 dBi

VSWR

<2:1

Radome Material UV Stable
Polyamide

Nominal Impedance

50 Ohm (nominal)

Max power

10 watts

Operating Temp

-40 to +80° C

Color Black





RF Antenna (Mushroom) **preferred:**

Electrical Specifications:

Center Frequency: 2.45GHz

Recom. Freq. Range: 2.4–2.5GHz

Wavelength: 1/2-wave

VSWR: ≤ 1.9 typical at center

Peak Gain: 3.5dBi

Impedance: 50-ohms

Connector: RP-SMA, SMA or U.FL / MHF

Cable: RG-174, RP-SMA & SMA
1.32 mm U.FL

Oper. Temp. Range: -40°C to +90°C

Max. Recom. Torque: 4.0 kgf-cm

*note that this is not the dome antenna tested in 2019

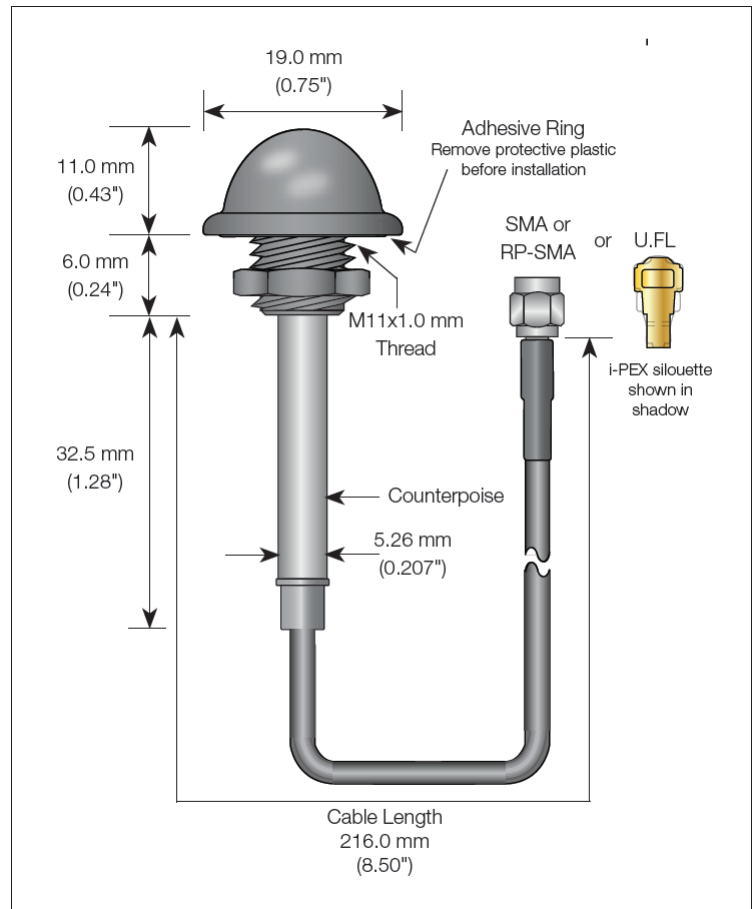

GPS Antenna

<https://eu.mouser.com/datasheet/2/238/ant-gps-sh2-ccc-1659160.pdf>

Electrical Specifications

Center Frequency

1575.42MHz, 1602MHz

Bandwidth

10MHz @ -3dB point

VSWR

1.5 typ. Antenna Peak Gain: 5.0dB typ.

Impedance

50-ohms

Axial Ratio 1.0dB typ.

Elev. Angle

5-90 degrees

Az. Bearing

360 degrees

Polarization RHCP

System Gain

28±1dB typ. (includes 3m cable & filter loss)

Noise Figure 1.0dB typ.

Input Voltage

+2.5 to +5.5VDC

Current

5-8mA typ. @ 5V

Mounting

Magnetic and/or screw

Cable

117" +/-6" (3m) RG-174U (Low-loss, 0.7dB/m)

Connection SMA, MCX, MMCX ¹

Weight

2.79oz (79g)

Plastic UV Resistance

UL-746C f1

Cable UV Resistance UL-758

Ingress Protection IP66

Temp. Range

-40°C to +85°C ²

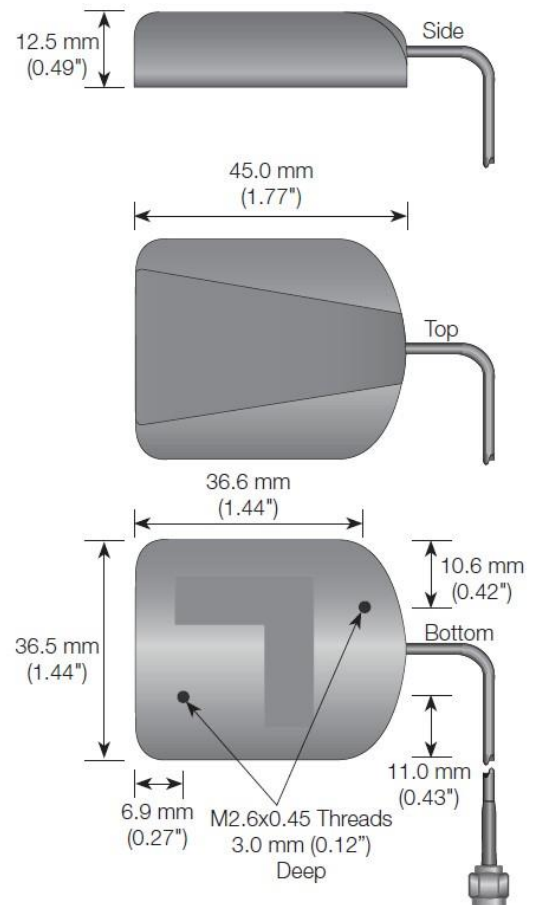

<https://eu.mouser.com/datasheet/2/238/ant-gps-sh2-ccc-1659160.pdf>



8.-Appendix 2: Pinout Detail

Mylap X2 Pro		
Connector Harness		ASU603-05SN
Connector X2		ASU003-05PN
Boot		203W301-25-G02
1	Vbat (8-18v)	Red
2	Gnd	Black
3	CAN_L	Green
4	CAN_H	White
5	Trigger	Free

Mylap X2 RF Link Pro		
Connector Harness		ASU603-05SN
Connector X2		ASU003-05PN
Boot		203W301-25-G02
1	Vbat (8-18v)	Red
2	Gnd	Black
3	CAN_L	Green
4	CAN_H	White
5	Open Collector	to TX Pin 5

9.-Appendix 3: CAN Message Detail Key

Messages are little endian unless stated

KEY	
Normal Black	Unchanged not compulsory
Normal Black	Unchanged compulsory
Normal Red	Changed not compulsory
Normal Red	Changed Compulsory
Normal Purple	2021 not compulsory
Normal Purple	2021 compulsory
<i>Normal Italic Blue</i>	For info only



9.-Appendix 3: CAN Message Detail

Summary of Addresses:					
Address	Description	Source	Route	Target	Notes
0x061	MyLaps Proprietary	X2 Trans	Local CAN		
0x0CC	TPMS MotoGP (600, 602/4 2D)	X2 Trans	-	-	-
0x0CD	COMM_TRANSMIT_QUEUE_STATUS	X2 Trans	Local CAN		
0x0CE	COMM_ID	X2 Trans	Local CAN		
0x0CF	COMM_FIRST_CONTACT	X2 Trans	Local CAN		
0x0D0	COMM_TIME	X2 Trans	Local CAN		
0x0D1	<i>BEACON_SETTING</i>	X2 Trans	Local CAN		
0x0D2	<i>BEACON_EVENT</i>	X2 Trans	Local CAN		
0x0D3	<i>ACCELEROMETER_XYX</i>	X2 Trans	Local CAN		
0x0D4					
0x0D5					
0x0D6					
0x0D7					
0x0D8	HEALTH_INFO (AND HEALTH FLAGS)	ECU	X2 RL	Race Direction	Used by solo ECU
0x0D9	X2-Link-TV	ECU	X2-RL	Tv Broadcast	-
0x0DA	<i>INFO_MSG</i>	<i>Race Dir</i>	<i>X2-RL</i>	<i>NA</i>	<i>Not used</i>
0x0DB	FLAGS_MSG_WSBK	Race Dir	X2 RL	Dashboard	
0x0DC	<i>BOX CALL/CLEAR_GP</i>	<i>Race Dir</i>	<i>X2-RL</i>	<i>NA</i>	Maybe flag ACK
0x0DD	<i>TIMING_NOTIFICATION_WSBK</i>	Race Dir	X2 RL	Dash/Team Log	
0x0DE	REV_REPORTS_WSBK (Low Rate for X2)	RevLogger	X2-RL	Race Direction	-
0x0DF	TPMS_WSBK	TPMS	X2-RL/CAN	Race Direction	Approved config
0x0E0	X2 STATUS	X2 RL	Local CAN	Team Logger	1hz
0x0E1	X2 VERSION	X2 RL	Local CAN	Team Logger	RTR response only
0x0E2	GPS FROM X2	X2 RL	Local CAN	Team Logger	5hz (future 10hz)
0x0E3	GPS TIME FROM X2	X2 RL	Local CAN	Team Logger	1hz (TX on second)
0x0E4	GPS EXT FROM X2	X2 RL	Local CAN	Team Logger	5hz (future 10hz)
0x0E5	Reserved (Heart Rate Etc)	-	-	-	-
0x0E6	-	-	-	-	-
0x0E7	-	-	-	-	-
0x0E8	REV_CONTROL_WSBK	ECU	Local CAN	Rev-Logger	-
0x0E9	REV_CONTROL_WSBK_2	ECU	Local CAN	Rev-Logger	-
0x0EA	REV_REPORTS_WSBK	RevLogger	Local CAN	Team Logger	-
0x0EB					
0x0EC					
0x0ED					
0x0EE					
0x0EF					
0x7FD	X2RL GPS old info				
0x7FE	X2RL GPS old info				



HEALTH_INFO (AND HEALTH FLAGS)

Type Transmitted Message (By ECU)
 Source ECU
 ID **0x0D8** (Was 0x0D4-D5)
 Length 8
 RTR No
 Rate 10Hz
 Note This is to begin understanding bike health data for Race Direction and potential future safety functions.

For Rider Does not have to be displayed to the rider.

0	1	2	3	4	5	6	7
Oil Pressure		Oil Temperature		H2O Temperature		Health Flags	ACK

Byte	Signal	Multiplier	Base Unit	Signing
Byte 0-1:	Oil Pressure	1	.1 bar	unsigned
Byte 2-3:	Oil Temperature	1	1° c	unsigned
Byte 4-5:	H2O Temperature	1	1° c	unsigned

Byte	Bit	ID
Byte 6	Bit 0	Oil Pressure Warning
	Bit 1	Oil Pressure Sensor Failure
	Bit 2	Oil Temp Warning
	Bit 3	Engine Temp Warning
	Bit 4	Other Warning
	Bit 5	Crashing Event
	Bit 6	Engine Off (by crash Strategy)
	Bit 7	Engine Off (Status)
Byte 7:	Bit 0	Penalty Acknowledge*
	Bit 1	Reserved
	Bit 2	Reserved
	Bit 3	Reserved
	Bit 4	Reserved
	Bit 5	Reserved
	Bit 6	Reserved
	Bit 7	Reserved

WSS300 and 600: Penalties should obscure the riders display, to recover the display they should acknowledge the penalty. The CAN message MUST transmit a confirmation TBC (20-8-20)



COMPETITOR BULLETIN 13-2025

* SBK: Not required

X2-Link-TV

Type Transmitted Message (By ECU)
 Source ECU
 ID **0x0D9**
 Length 8
 RTR Capable NO
 Rate **15-25Hz** Depending on the rates available in the system

0	1	2	3	4	5	6	7
Speed		Gear	Fr-Brake	Throttle	Lean Angle	RPM	

Byte	Signal	Multiplier	Base Unit	Signing
Byte-0-1	Speed	1	1 km/h	unsigned
Byte-2	Gear	1	1	unsigned
Byte-3	Fr-Brake	%, 100% = Team-max pres		unsigned
Byte-4	TPS-Grip	1	1%	unsigned
Byte-5	Lean-Angle, LH, RH+	1	1°	signed
Byte-6-7	RPM	1	1 rpm	unsigned

Fr-Brake, this is to enable a graphical representation of riders brake pressure. Due to different brake systems the manufacturer should individually define max pressure, it should be between 12 bar and 16bar to ensure consistent graphics (FYI MotoGP defines 15 bar as 100%)



COMPETITOR BULLETIN 13-2025

FLAGS_MSG_WSBK

Type Received Message
 Source X2 Link (Race Control)
 ID 0x0DB
 Length 8
 RTR Capable NO
 Note

Flags and messages should occupy different areas and one flag and one message can be simultaneously active.

0	1	2	3	4	5	6	7
FLAGS 1	FLAGS 2	PENALTY	POSITION	TIME			

Race direction sends this message. Only the messages marked as compulsory (Byte 0-4) MUST be displayed to the rider.

In the message any bit set to 1 indicates that the related flag or penalty is active. Any previous active flag or penalty must be deactivated when receiving a message with its specific bit set to 0.

The following groups of flags are grouped as flags that are track sector based and flags that specific to one or more riders.

As with trackside lightboards the aim is to only need one 'light' active at a time. In the case where two flags could be used trackside only the more important flag signal will be transmitted. For example, Red with Double Yellow when the riders are returning to the pits. In this case only the Red Flag will be transmitted - the double flags will still be used in the relevant sectors trackside.

Byte 0	FLAGS 1	Type = "Flag", for track sector		CANCEL
	Bit 0	Green Flag		Race Dir
	Bit 1	Yellow and Red Striped Flag		Race Dir
	Bit 2	White Flag with diagonal Red Cross		Race Dir
	Bit 3	White Flag		Race Dir
	Bit 4	Red flag		Race Dir
	Bit 5	Yellow Flag		Race Dir
	Bit 6	Yellow Flag Double (can flash)		Race Dir
	Bit 7	Safety Car		Race Dir
Byte 1	FLAGS 2	Type = "Flag", for track sector		
	Bit 0	Black Flag		Race Dir
	Bit 1	Black Flag with Orange disk		Race Dir
	Bit 2	Blue Flag		Race Dir
	Bit 3	Chequered Black/White flag		
	Bit 4	Reserved		
	Bit 5	Reserved		
	Bit 6	Reserved		
	Bit 7	Rain Light (use to switch light, not as message)*	TBC	



COMPETITOR BULLETIN 13-2025

Byte 2	PENALTY	Type = "Message", for rider		
	Bit 0	Ride Through		Race Dir
	Bit 1	Drop Position		Race Dir
	Bit 2	Exceeding Track limits* can be overwritten by warnings		Race Dir
	Bit 3	Time Penalty* can be overwritten by warnings		Race Dir
	Bit 4	Long Lap Penalty		Race Dir
	Bit 5	Double Long Lap Penalty		Race Dir
	Bit 6	Go to position		Race Dir
	Bit 7	Enter Pitlane (grid problem or behind safety)		Race Dir
Byte 3	POSITION	Type = "Message", for riders		
		Number of positions that must be dropped due to a penalty, for instance, after an overtaking under yellow flag (used on "Drop Position" Penalty). AND used by x minutes board - 5 or 3 minutes		
Byte 4	TIME	Type = "Message", for rider		
		10ths of second that will be added at end of session or race		

Safety Car: Not required for WSBK but required in National Championships



COMPETITOR BULLETIN 13-2025

Rain Light: In WSS300 and WSS600 it is compulsory that the rain light is switched by the CAN message (in addition to a button). The CAN message has priority. In WSBK it will be compulsory from 2022 and recommended now.

TIMING_NOTIFICATION_WSBK (TEAM_NOTIFICATION_GP)

Type Received Message
 Source X2-Link (Team)
 ID **0x0DD**
 Length 8
 RTR Capable NO
 Note This message is created by timekeeping NOT a team message as in MotoGP

0	1	2	3	4	5	6	7
Type	Data1	Data2	Data3	Data4	Data5	Data6	Reserved

Value	Type	-
1	Practice Info	
2	Race Info	
3	Opponent Info	
4	Suggested mapping	
5	Being followed	
6	Racer KO	
7	Penalty Warning	
8	Bike Ready	
9	Tyre Specs	

Depending on the message type, the following bytes will include specific information. Described bit fields will be packed from MSB to LSB, some messages will just use DATA1 while others may use all bytes from DATA1 to DATA6.



COMPETITOR BULLETIN 13-2025

-	-	-	Bit length	Min	Max	Scale/Unit	-	As MGP
Type 1	Practice Information		-	-	-	-	-	-
-	Position	6 bits	1	63	1	Optional	*	
-	P1 Time	11 bits	1	2047	.1 second	Optional	*	
-	Target Time	11 bits	1	2027	.1 second	Optional	*	
-	Remaining Time	12 bits	1	4095	1 second	Optional	*	
-	-	-	-	-	-	-	-	
Type 2	Race Info		-	-	-	-	-	
-	Position	6	1	63	1	Future/Opt	*	
-	Racer Ahead	7	1	99	#	Future/Opt	*	
-	Gap Ahead	10	1	1023	1	Future/Opt	*	
-	Racer Behind	7	1	99	#	Future/Opt	*	
-	Gap Behind	10	1	1023	1	Future/Opt	*	
-	Remaining Laps	6	1	63	1	Optional	*	
-	-	-	-	-	-	-	-	
Type 3	Opponent Info		-	-	-	-	-	
-	Racer	7	1	99	1	Not used	*	
-	Tyre Type	2	1	3	1	Not used	*	
-	Tyre Front	3	1	5	1	Not used	*	
-	Tyre Rear	3	1	5	1	Not used	*	
-	Lap Time	11	1	2047	.1s	Not used	*	
-	Gap	10	1	1023	.1s	Not used	*	
-	-	-	-	-	-	-	-	
Type 4	Suggested Mapping		-	-	-	-	-	
-	Map	8	1	10	1	Not used	*	
-	-	-	-	-	-	-	-	
Type 5	Being Followed		-	-	-	-	-	
-	Racer	8	1	99	#	Not used	*	
-	-	-	-	-	-	-	-	
Type 6	Racer Out		-	-	-	#	-	
-	Racer Out	8	1	99	-	Not used	*	
-	-	-	-	-	-	-	-	
Type 7	Penalty Warning		-	-	-	-	Not used	
-	-	-	-	-	-	-	-	
Type 8	Bike Specs (Spare)		-	-	-	-	-	
-	Tyre Type	2	1	3	-	Future/Opt	*	
-	Tyre Front	3	1	5	-	Future/Opt	*	
-	Tyre Rear	3	1	5	-	Future/Opt	*	
-	-	-	-	-	-	-	-	
Type 9	Tyre Option (current use rider info)		-	-	-	-	-	
-	Tyre Type	2	1	3	-	Future/Opt	*	
-	Tyre Front	3	1	5	-	Future/Opt	*	
-	Tyre Rear	3	1	5	-	Future/Opt	*	
-	Tyre Front # from allocation	6	1	63	-	Future/Opt	-	
-	Tyre Rear # from allocation	6	1	63	-	Future/Opt	-	



REV_REPORTS_WSBK (Low Rate for X2 Link)

Type Transmitted Message (Transmitted by Rev logger)
 Source Rev Logger
 ID **0x0DE**
 Length 8
 RTR-Capable NO
 Rate **10Hz**

0	1	2	3	4	5	6	7
Info bits		Exceptions		Time exceeded		RL Calculated RPM	

Byte	Bit	Signal	Note	Signing
Bytes 0-1	Bit 0-13	RPM Limit	rpm limit set point (16383 max)	Unsigned
	Bit 14	Limit Exceed	Rev Limit! Exceed momentary	Unsigned
	Bit 15	Max time exceed	Race direction flag - max time exceeded	Unsigned
Byte 2-3	-	Exception	# Times limiter has been exceeded	Unsigned
Byte 4-5	-	Time exceeded	Milliseconds, maximum 65 seconds	Unsigned
Byte 6-7	-	RL Calc RPM	The RPM as recorded by the rev limiter	Unsigned

TPMS_INFO

Type Transmitted Message
 Source TPMS System (not bridged by ECU), example .ldd file available
 ID **0x0DF**
 Length 8
 RTR No
 Align Big Endian
 Signed All Signed
 Rate 3 - 12.5Hz

0	1	2	3	4	5	6	7
FR ID		FR. TEMP	FR.PRESS	RR ID		RR TEMP	RR PRESS

Contact bsbtechnical@msvracing.co.uk to request a 2D .LDD configuration file, this requires the 2D 'MotoGP firmware'. All systems must be from the approved parts list (2D and i2m currently)



X2

Status

Type Transmitted Message
 Source X2 Racelink
 ID 0x0E0
 Length 8
 RTR No
 Align Big Endian
 Rate 1hz

0	1	2	3	4	5	6	7
X2RL_F RSSI	GPS_X2RL_Sats	Input Volt	Batt Lvl	Flags	GPS_X2RL_HDOP		

Byte	Signal	Multiplier	Base Unit	Signing
Byte 0	RF RSSI	1	dBm	signed
Byte 1	GPS Sat	1		unsigned
Byte 2	Input Voltage	10	Volt	unsigned
Byte 3	Battery Level	1	%	unsigned
Byte 4	Flags	1	b0: GPS Fix Valid	unsigned
Byte 5	GPS HDOP	10		unsigned

X2 Version

Type Transmitted Message
 Source X2 Racelink
 ID 0x0E1
 Length 8
 RTR Yes
 Align Big Endian
 Signed All Signed
 Rate RTR only

0	1	2	3	4	5	6	7
Device ID				Firmware	Hardware	Firmware	

Byte	Signal	Signing
Byte 0-3	Device ID	Unsigned
Byte 4	Firmware Minor	Unsigned
Byte 5	Hardware	Unsigned
Byte 6	Firmware Major	Unsigned



X2 Location (GPS)

Type Transmitted Message
 Source X2 Racelink
 ID 0x0E2
 Length 8
 RTR No
 Align Big Endian
 Signed All Signed
 Rate 5hz

0	1	2	3	4	5	6	7
GPS_X2RL_Latitude				GPS_X2RL_Longitude			

Byte	Signal	Multiplier	Base Unit	Signing
Byte 0-3	GPS_X2RL_Speed	1.00E-07	Degrees	Signed
Byte 4-7	GPS_X2RL_Altitude	1.00E-07	Degrees	Signed

X2 Time (GPS)

Type Transmitted Message
 Source X2 Racelink
 ID 0x0E3
 Length 8
 RTR No
 Align Big Endian
 Signed All Signed
 Rate 1hz (on the second)

0	1	2	3	4	5	6	7
GPS_X2RL_Time						None	

Byte	Signal	Multiplier	Base Unit	Notes
Byte 0-5	GPS_X2RL_Time	1	second	unified GPS time



X2 Location (Extended) (GPS)

Type Transmitted Message
 Source X2 Racelink
 ID **0x0E4**
 Length 8
 RTR No
 Align Big Endian
 Signed All Signed
 Rate 5hz

0	1	2	3	4	5	6	7
GPS_X2RL_Speed		GPS_X2RL_Heading		GPS_X2RL_Altitude			

Byte	Signal	Multiplier	Base Unit	Signing
Byte 0-1	GPS_X2RL_Speed	1	1 km/h	Unsigned
Byte 2-3	GPS_X2RL_Heading	1	Degrees	Signed
Byte 4-7	GPS_X2RL_Altitude	100	Metres	Signed

REV_CONTROL_WSBK

Type Transmitted Message (from ECU) and logged
 Source ECU
 ID **0x0E8**
 Length 8
 RTR Capable NO
 Rate 100Hz

0	1	2	3	4	5	6	7
RPM		Front speed		Rear Speed		Brake Front (Actual)	

Byte	Signal	-	Multiplier	Base Unit	Signing
Byte 0-1	RPM		1	1 rpm	Unsigned
Byte 2-3	Speed		1	1 km/h	Unsigned
Byte 4-5	Speed		1	1 km/h	Unsigned
Byte 6-7	Brake		1	0.1 bar	Unsigned



REV_CONTROL2_WSBK

Type Transmitted Message (from ECU) and logged
 Source ECU
ID 0x0E9
 Length 8
 RTR-Capable NO
 Rate 100Hz

0	1	2	3	4	5	6	7
TPS Grip		TPS1		TPS2		Lean	

Byte	Signal	Multiplier	Base Unit	Signing
Byte 0-1	TPS Grip	1	0.10%	Signed
Byte 2-3	TPS 1	1	0.10%	Signed
Byte 4-5	TPS 2	1	0.10%	Signed
Byte 6-7	Lean Angle, LH-, RH+	1	1°	Signed

REV_REPORTS_WSBK

Type Transmitted Message (Transmitted by Rev logger)
 Source Rev Logger
ID 0x0EA
 Length 8
 RTR-Capable NO
 Rate 100Hz

0	1	2	3	4	5	6	7
Info bits		Exceptions		Time exceeded		RL Calculated RPM	

Byte	Bit	Signal	Note	Signing
Bytes 0-1	Bit 0-13	RPM Lim	rpm limit set point (16383 max)	Unsigned
-	Bit 14	Limit Exceed	Rev Limit Exceed momentary	Unsigned
-	Bit 15	Max time exceed	Race direction flag - max time exceeded	Unsigned
Byte 2-3	-	Exception	#Times limiter has been exceeded	Unsigned
Byte 4-5	-	Time exceeded	Milliseconds, maximum 65 seconds	Unsigned
Byte 6-7	-	RL Calc RPM	The RPM as recorded by the rev limiter	Unsigned



10.-Appendix 4: Spare Parts

It is the team's responsibility to ensure that they have spare parts and that the system is kept in working order. By managing your own parts you will also be able to customise the lengths of the RF cabling to better suit your machines. The system uses SMA and RP-SMA connectors that are commonly available along with the crimping tools (cheap)

X2 Link Unit:

Mylaps: Alessandro Bianchi (Alessandro.Bianchi@mylaps.com)

GPS Aerial:

Spec: <https://eu.mouser.com/datasheet/2/238/ant-gps-sh2-ccc-1659160.pdf>

Mouser: 712-ANT-GPS-SH2-SMA

<https://www.mouser.co.uk/ProductDetail/Linx-Technologies/ANT-GPS-SH2-SMA?qs=1mbolxNpo8f%252BCn7vpY8saq==>

Component-Store: ANT-GPS-SH2-SM

<https://www.components-store.com/product/Linx-Technologies/ANT-GPS-SH2-SMA.html>

RS: 202-5851

https://uk.rs-online.com/web/p/gps-antennas/2025851?cm_mmc=UK-PPC-DS3A--google--3_UK_EN_GPS+Antennas_Linx_Exact--Linx++GPS+Antennas++2025851+-+5--ant+gps+sh2+sma&matchtype=e&kwd-984674068247&s_kwcid=AL!7457!3!452567429901!e!g!!ant%20gps%20sh2%20sma&gclid=CjwKCAjw97P5BRBQEIwAGfV6XJa3Kw9J6qShCKK37QT1VTOhL40AcsGdeL4PcOuoFp6hZn5YIzuMxoCfpwQAvD_BwE&qclsrc=aw.ds

Digi-Key: ANT-GPS-SH2-SMA-ND

<https://www.digikey.com/en/products/detail/linx-technologies-inc/ANT-GPS-SH2-SMA/7323769>

RF Mushroom Antenna:

Digikey: ANT-2.4-WRT-MON-UFL-ND

https://www.digikey.es/product-detail/es/linx-technologies-inc/ANT-2.4-WRT-MON-UFL/ANT-2.4-WRT-MON-UFL-ND/4576776?utm_adgroup=RF%20Antennas&utm_source=google&utm_medium=cpc&utm_campaign=Shopping_Product_RF%20FIF%20and%20RFID&utm_term=&productid=4576776&gclid=Cj0KCOjw-uH6BRDQARIsAI3I-Uc4sXB54r-6Q5mPG89I_enMSTVTaM0SILE74p7Vq-1rO4QPzHZnLDQaAqstEALw_wcB

Mouser: 712-ANT-2.4-WRT-UFL

<https://www.mouser.co.uk/ProductDetail/Linx-Technologies/ANT-24-WRT-MON-UFL?qs=M80ie1ekFqNnGafOCwOqvA==>